

**FRESATRICE  
ROTARY TILLER  
FRASE  
FRAISE**

**FBA**

**093.122.1**

**CATALOGO RICAMBI  
SPARE PARTS CATALOGUE  
ERSATZTEILKATALOG  
CATALOGUE DE PIECES DETACHEES**



**1955**

**Celli S.p.A.** Via Masetti, 32 - 47122 Forlì (Italy)  
Tel. 0543 794711 - Fax. 0543 794747  
[www.celli.it](http://www.celli.it)



### Avvertenze importanti

Per ordinazioni di parti di ricambio è necessario indicare sempre i seguenti dati:

- modello della macchina,
- numero di matricola,
- codice del particolare,
- denominazione corrispondente,
- numero dei pezzi,
- istruzioni per le spedizioni.

Solo seguendo queste norme sarete sicuri di una sollecita evasione dell'ordine.

Qualora manchino i dati sopraindicati oppure sussistano dubbi sulla scelta del particolare di ricambio, per evitare disguidi, è consigliabile corredare l'ordine di tutte le informazioni possibili o recapitarci il pezzo avariato.

### Important

When ordering spare parts please, quote:

- model of the machine,
- serial number,
- spare part code number,
- description,
- quantity,
- forwarding instructions.

Only following this procedure will you secure a prompt service. Should you not be able to supply any of the details listed above or should there be any doubt regarding the type of spare parts required, please enclose with order supplementary information and description or, when possible, send damaged part.

### Avertissements importants

Pour des commandes de pièces de rechange il est nécessaire d'indiquer toujours les suivantes données:

- modèle de la machine,
- numéro de série,
- code de la pièce,
- dénomination correspondante,
- nombre de pièce,
- instructions pour les expéditions.

C'est seulement en suivant ces normes que vous aurez d'une prompte exécutions de l'ordre.



Au cas où il manquerait les données ci-dessus indiquées ou bien s'il subsiste des doutes, pour éviter tous risques il est conseillé de communiquer avec l'ordre tous les renseignements possibles ou de nous faire parvenir la pièce endommagée.

### Wichtig:

Bei Bestellungen von Ersatzteilen ist folgendes zu beachten:

- Modell der Maschine,
- Serien-Nummer der Maschine,
- zusätzliche Bezeichnungen,
- Code-Nummer des Ersatzteiles,
- Anzahl der Ersatzerte,
- Anweisungen für den Versand.

Die Auslieferung kann nur dann erfolgen, wenn all die obengenannten Anweisungen befolgt worden sind. Falls gewisse Angaben fehlen oder Zweifel bestehen, bitte defekte Teile einsenden.

<b>CELLI S.p.A.</b> Via Masetti 32 47122 FORLI' - ITALIA <a href="http://www.celli.it">www.celli.it</a>		
<b>Mod.</b>	<input type="text"/>	
<b>N°</b>	<input type="text"/>	
<b>Kg</b>	<input type="text"/>	<b>Made in Italy</b>
<b>Anno</b>	<input type="text"/>	
Lubrificanti raccomandati Recommended lubricants Lubrifiants recommandés Empfohlene schmiere		

### IDENTIFICAZIONE DELLA MACCHINA

Il modello ed il numero di matricola sono riportati sulla targhetta metallica fissata al cofano della macchina.

N.B.: Per ogni richiesta precisare sempre i dati: modello e numero di telaio.

### IDENTIFICATION

Type and size of machine and serial number are stamped on the metal plate fixed on the top of the main frame; they should be quoted when asking for spares or information.

### IDENTIFICATION DE LA MACHINE

Le modèle et le numéro de série sont reportés sur la plaquette métallique fixée sur la machine.

N.B.: Pour demande préciser toujours les données: modèle et numéro de série.

### IDENTIFIKATION DER MACHINE

Typ und Serien-Nummer sind auf das Schild an der Schutzhaube der Maschine zu übertragen.

N.B.: Bei Anfragen die Darten der Serien-Nummer und des Modell typs angeben.



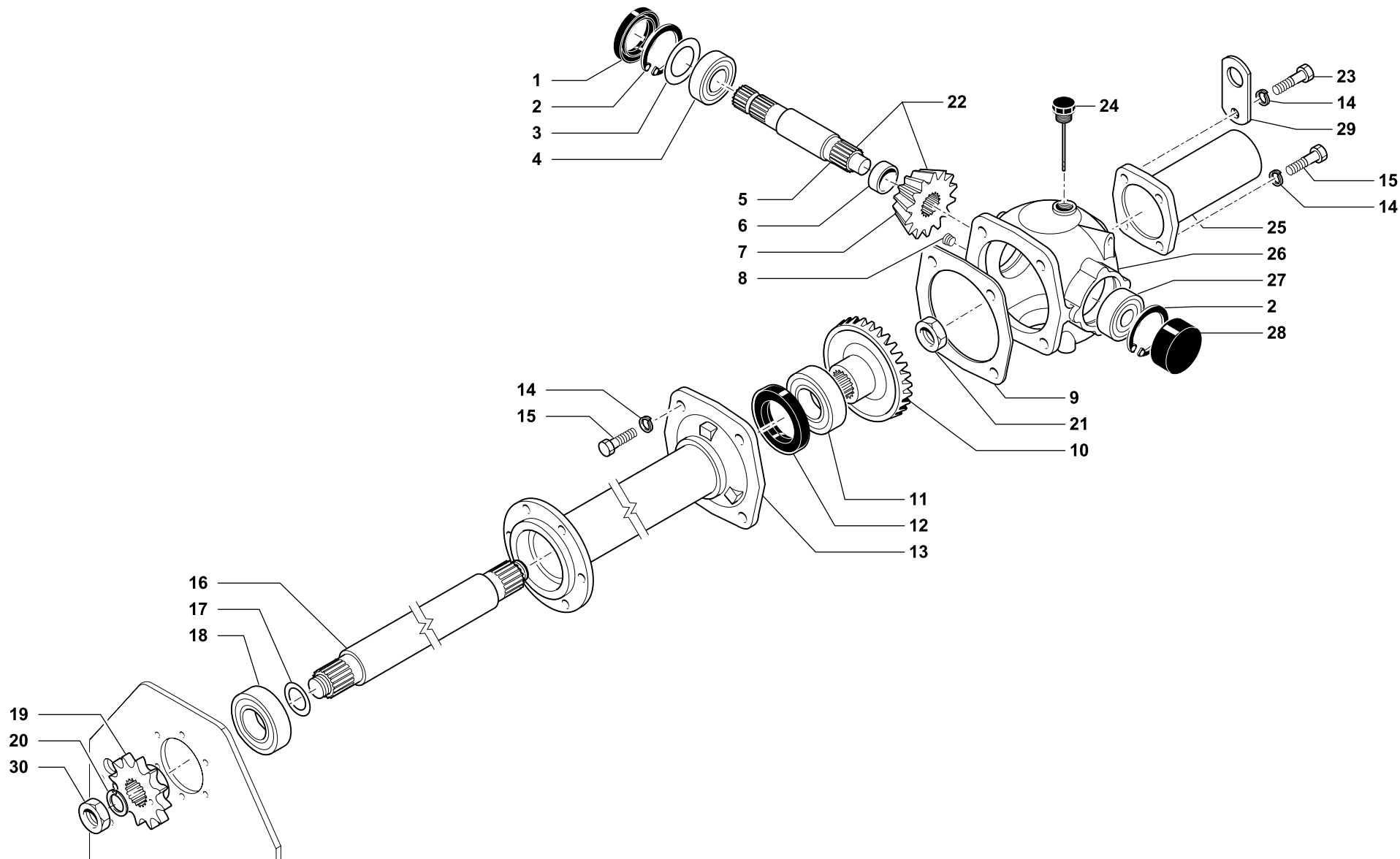

SCATOLA CAMBIO 1 VELOCITA' 540-750 giri/min • 1 SPEED GEARBOX 540-750 rpm  
 1-GANG-WECHSEBADGETRIEBE 540-750 U/min • BOITIER 1 VITESSE 540-750 t/mm

Tav. Tab. Taf.	<b>122.465</b>	Rev.	<b>01</b>	<b>0713</b>
----------------------	----------------	------	-----------	-------------



**SCATOLA CAMBIO 1 VELOCITA' 540-750 giri/min • 1 SPEED GEARBOX 540-750 rpm**  
**1-GANG-WECHSEBADGETRIEBE 540-750 U/min • BOITIER 1 VITESSE 540-750 t/mm**

Tav.  
Tab.  
Taf.

**122.465**

Rev. **01**

**0713**

RIF.	CODICE	DESCRIZIONE	DENOMINATION	BEZEICHNUNG	DENOMINATION	
	1	007028	Paraolio	Oil seal	Simmerring	Joint huile
	2	001006	Anello di arresto	Stop ring	Sperring	Bague d'arret
	3	001123	Serie spessori	Set spacers	Beilagscheiben	Serie d'epaisseurs
	4	003051S	Cuscinetto	Bearing	Kugellager	Roulement
	5	332500	Albero	Shaft	Welle	Arbre
540 rpm	6	323553	Distanziale	Spacer	Distanzstueck	Entretoise
	7	331514	Pignone Z13	Pinion	Kegelrad	Pinion
	8	022009	Tappo	Plug	Verschluss	Bouchon
	9	333500	Guarnizione	Gasket	Dichtring	Joint
540 rpm	10	331515	Corona Z22	Crownwheel	Zahnkranz	Couronne
750 rpm		331532	Corona Z23	Crownwheel	Zahnkranz	Couronne
	11	003145	Cuscinetto	Bearing	Kugellager	Roulement
	12	007042	Paraolio	Oil seal	Simmerring	Joint huile
95	13	561839	Distanziale	Spacer	Distanzstueck	Entretoise
105		561833	Distanziale	Spacer	Distanzstueck	Entretoise
125		561834	Distanziale	Spacer	Distanzstueck	Entretoise
145		561835	Distanziale	Spacer	Distanzstueck	Entretoise
165		561836	Distanziale	Spacer	Distanzstueck	Entretoise
	14	011003	Grower	Grower	Federscheibe	Grower
	15	014145	Vite	Screw	Schraube	Vis
95	16	523699	Semiasse	Axle shaft	Achswelle	Demi-axe
105		523693	Semiasse	Axle shaft	Achswelle	Demi-axe
125		523694	Semiasse	Axle shaft	Achswelle	Demi-axe
145		523695	Semiasse	Axle shaft	Achswelle	Demi-axe
165		523696	Semiasse	Axle shaft	Achswelle	Demi-axe
	17	001115	Rondella	Washer	Scheibe	Rondelle
	18	003002	Cuscinetto	Bearing	Kugellager	Roulement
	19	522518	Ingranaggio	Gear	Zahnrad	Engrenage
	20	511550	Rondella	Washer	Scheibe	Rondelle
	21	005007	Ghiera	Ring nut	Nutmutter	Collier
540 rpm	22	331514	Albero pignone Z13	Pinion shaft	Arbre pignon	Ritzelwelle
750 rpm		331531	Albero pignone Z9	Pinion shaft	Arbre pignon	Ritzelwelle

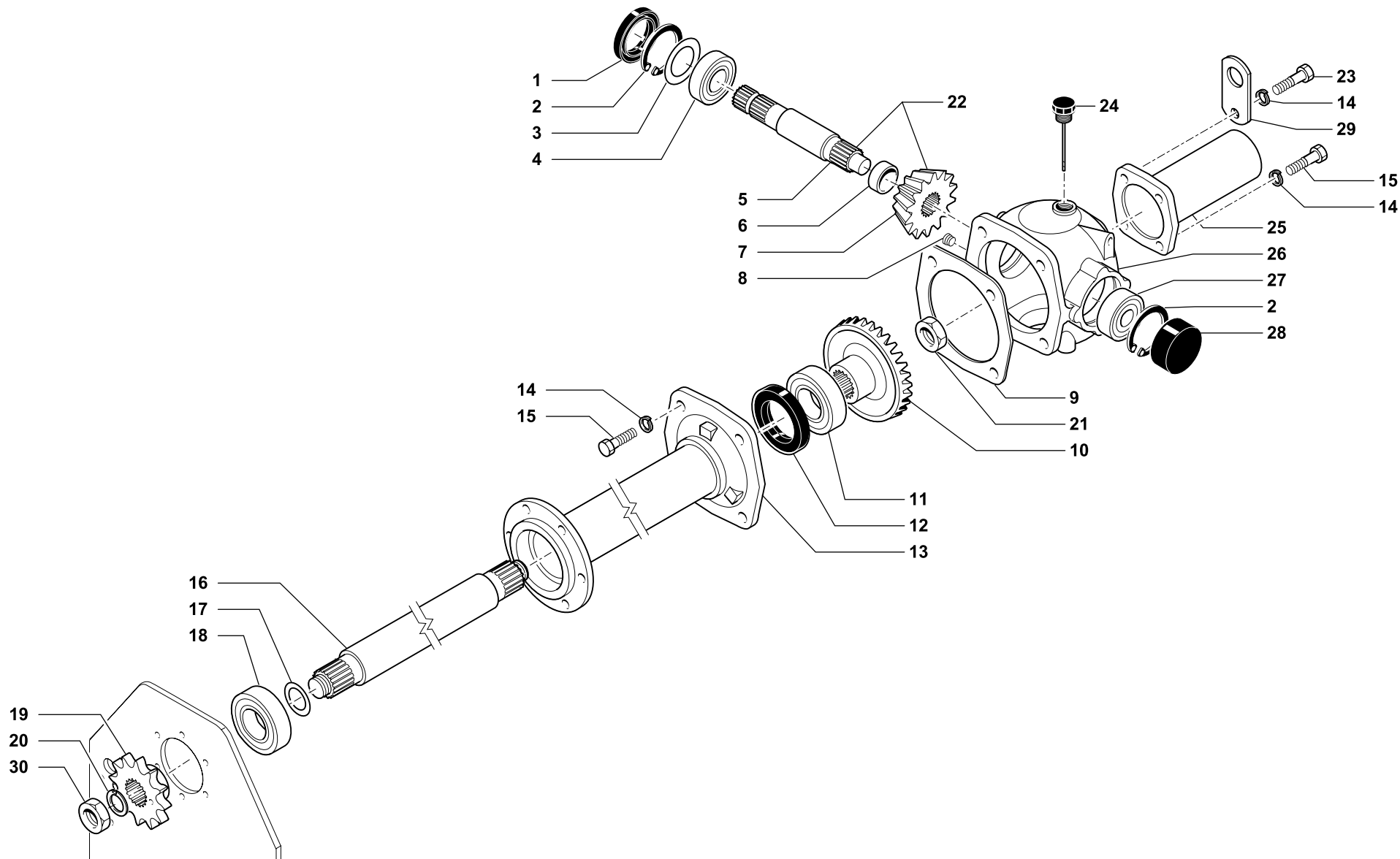

SCATOLA CAMBIO 1 VELOCITA' 540-750 giri/min • 1 SPEED GEARBOX 540-750 rpm  
 1-GANG-WECHSEBADGETRIEBE 540-750 U/min • BOITIER 1 VITESSE 540-750 t/mm

Tav. Tab. Taf.	<b>122.465</b>	Rev.	<b>01</b>	<b>0713</b>
----------------------	----------------	------	-----------	-------------



**SCATOLA CAMBIO 1 VELOCITA' 540-750 giri/min • 1 SPEED GEARBOX 540-750 rpm**  
**1-GANG-WECHSEBADGETRIEBE 540-750 U/min • BOITIER 1 VITESSE 540-750 t/mm**

Tav.  
Tab.  
Taf.

**122.465**

Rev.

**01**

**0713**

RIF.	CODICE	DESCRIZIONE	DENOMINATION	BEZEICHNUNG	DENOMINATION
23	014213	Vite	Screw	Schraube	Vis
24	022091	Tappo	Plug	Verschluss	Bouchon
25	561825	Supporto	Support	Halterung	Support
26	330500	Scatola	Housing	Gehäuse	Bôte
27	003041	Cuscinetto	Bearing	Kugellager	Roulement
28	333512	Coperchio	Cover	Deckel	Couvercle
29	523686	Piastra	Plate	Teller	Plateau
30	332504	Dado	Nut	Mutter	Ecrou



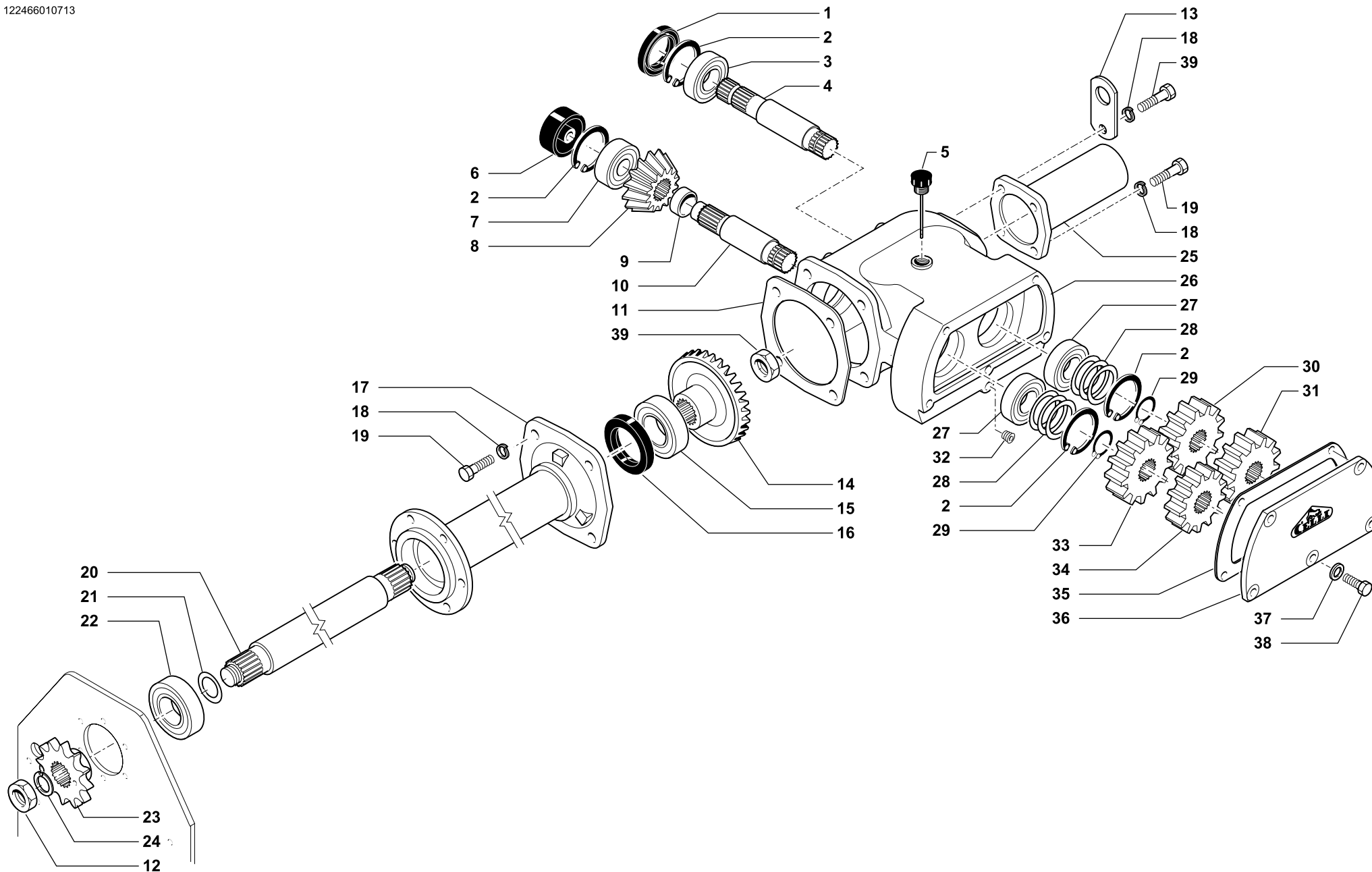

SCATOLA TRASMISSIONE 4 VELOCITA' 540 giri/min • 4 SPEED GEARBOX 540 rpm  
 GETRIEBEGEHÄUSSE 4 GESCHW. 540 U/min • BOITIER 4 VITESSES 540 t/mm

Tav. Tab. Taf.	<b>122.466</b>	Rev.	<b>01</b>	<b>0713</b>
----------------------	----------------	------	-----------	-------------



SCATOLA TRASMISSIONE 4 VELOCITA' 540 giri/min • 4 SPEED GEARBOX 540 rpm  
GETRIEBEGEHÄUSSE 4 GESCHW. 540 U/min • BOITIER 4 VITESSES 540 t/mm

Tav.  
Tab.  
Taf.

122.466

Rev.

01

0713

RIF.	CODICE	DESCRIZIONE	DENOMINATION	BEZEICHNUNG	DENOMINATION
1	007028	Paraolio	Oil seal	Simmerring	Joint huile
2	001006	Anello di arresto	Stop ring	Sperring	Bague d'arret
3	003051S	Cuscinetto	Bearing	Kugellager	Roulement
4	332501	Albero	Shaft	Welle	Arbre
5	022091	Tappo	Plug	Verschluss	Bouchon
6	333512	Coperchio	Cover	Deckel	Couvercle
7	003041	Cuscinetto	Bearing	Kugellager	Roulement
8	331514	Pignone	Pinion	Kegelrad	Pinion
9	323553	Distanziale	Spacer	Distanzstueck	Entretoise
10	332502	Albero	Shaft	Welle	Arbre
11	333500	Guarnizione	Gasket	Dichtring	Joint
12	332504	Dado	Nut	Mutter	Ecrou
13	523686	Piastra	Plate	Teller	Plateau
14	331515	Corona	Crownwheel	Zahnkranz	Couronne
15	003145	Cuscinetto	Bearing	Kugellager	Roulement
16	007042	Paraolio	Oil seal	Simmerring	Joint huile
95	17 561838	Distanziale	Spacer	Distanzstueck	Entretoise
105	561832	Distanziale	Spacer	Distanzstueck	Entretoise
125	561833	Distanziale	Spacer	Distanzstueck	Entretoise
145	561834	Distanziale	Spacer	Distanzstueck	Entretoise
165	561835	Distanziale	Spacer	Distanzstueck	Entretoise
18	011003	Grower	Grower	Federscheibe	Grower
19	014145	Vite	Screw	Schraube	Vis
95	20 523698	Semiasse	Axle shaft	Achswelle	Demi-axe
105	523692	Semiasse	Axle shaft	Achswelle	Demi-axe
125	523693	Semiasse	Axle shaft	Achswelle	Demi-axe
145	523694	Semiasse	Axle shaft	Achswelle	Demi-axe
165	523695	Semiasse	Axle shaft	Achswelle	Demi-axe
21	001115	Rondella	Washer	Scheibe	Rondelle
22	003002	Cuscinetto	Bearing	Kugellager	Roulement
23	522518	Ingranaggio	Gear	Zahnrad	Engrenage
24	511550	Rondella	Washer	Scheibe	Rondelle

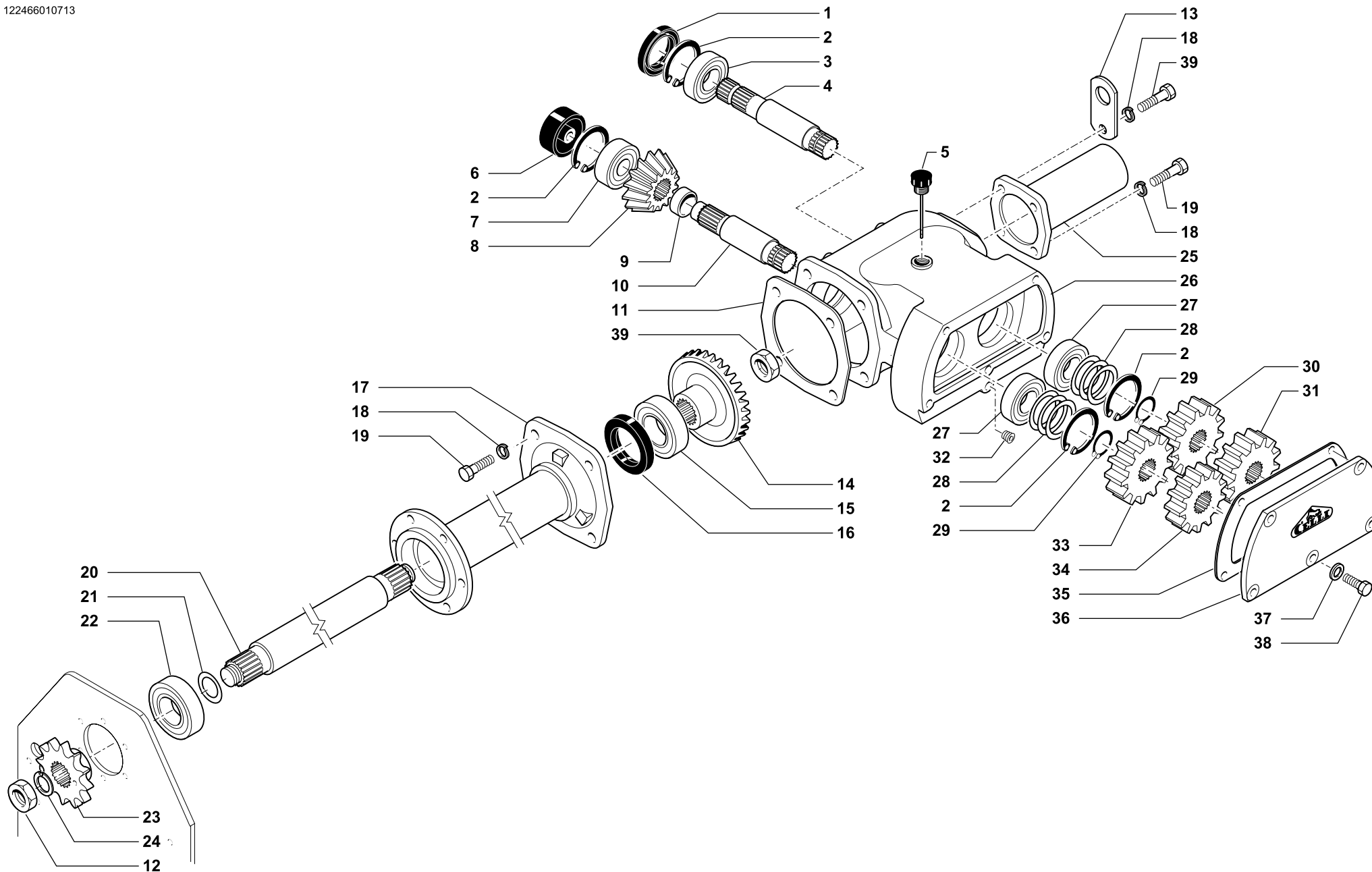

SCATOLA TRASMISSIONE 4 VELOCITA' 540 giri/min • 4 SPEED GEARBOX 540 rpm  
 GETRIEBEGEHÄUSSE 4 GESCHW. 540 U/min • BOITIER 4 VITESSES 540 t/mm

Tav. Tab. Taf.	<b>122.466</b>	Rev.	<b>01</b>	<b>0713</b>
----------------------	----------------	------	-----------	-------------



SCATOLA TRASMISSIONE 4 VELOCITA' 540 giri/min • 4 SPEED GEARBOX 540 rpm  
GETRIEBEGEHÄUSSE 4 GESCHW. 540 U/min • BOITIER 4 VITESSES 540 t/mm

Tav.  
Tab.  
Taf.

**122.466**

Rev.

**01**

**0713**

RIF.	CODICE	DESCRIZIONE	DENOMINATION	BEZEICHNUNG	DENOMINATION
25	561825	Supporto	Support	Halterung	Support
26	330501	Scatola	Housing	Gehäuse	Bôte
27	003074	Cuscinetto	Bearing	Kugellager	Roulement
28	001123	Serie spessori	Set spacers	Beilagscheiben	Serie d'épaisseurs
29	001020	Anello di arresto	Stop ring	Sperring	Bague d'arret
30	331507	Ingranaggio	Gear	Zahnrad	Engrenage
31	331508	Ingranaggio	Gear	Zahnrad	Engrenage
32	022009	Tappo	Plug	Verschluss	Bouchon
33	331506	Ingranaggio	Gear	Zahnrad	Engrenage
34	331505	Ingranaggio	Gear	Zahnrad	Engrenage
35	333501	Guarnizione	Gasket	Dichtring	Joint
36	330502	Coperchio	Cover	Deckel	Couvercle
37	011012	Rondella	Washer	Scheibe	Rondelle
38	014205	Vite	Screw	Schraube	Vis
39	005007	Ghiera	Ring nut	Nutmutter	Collier

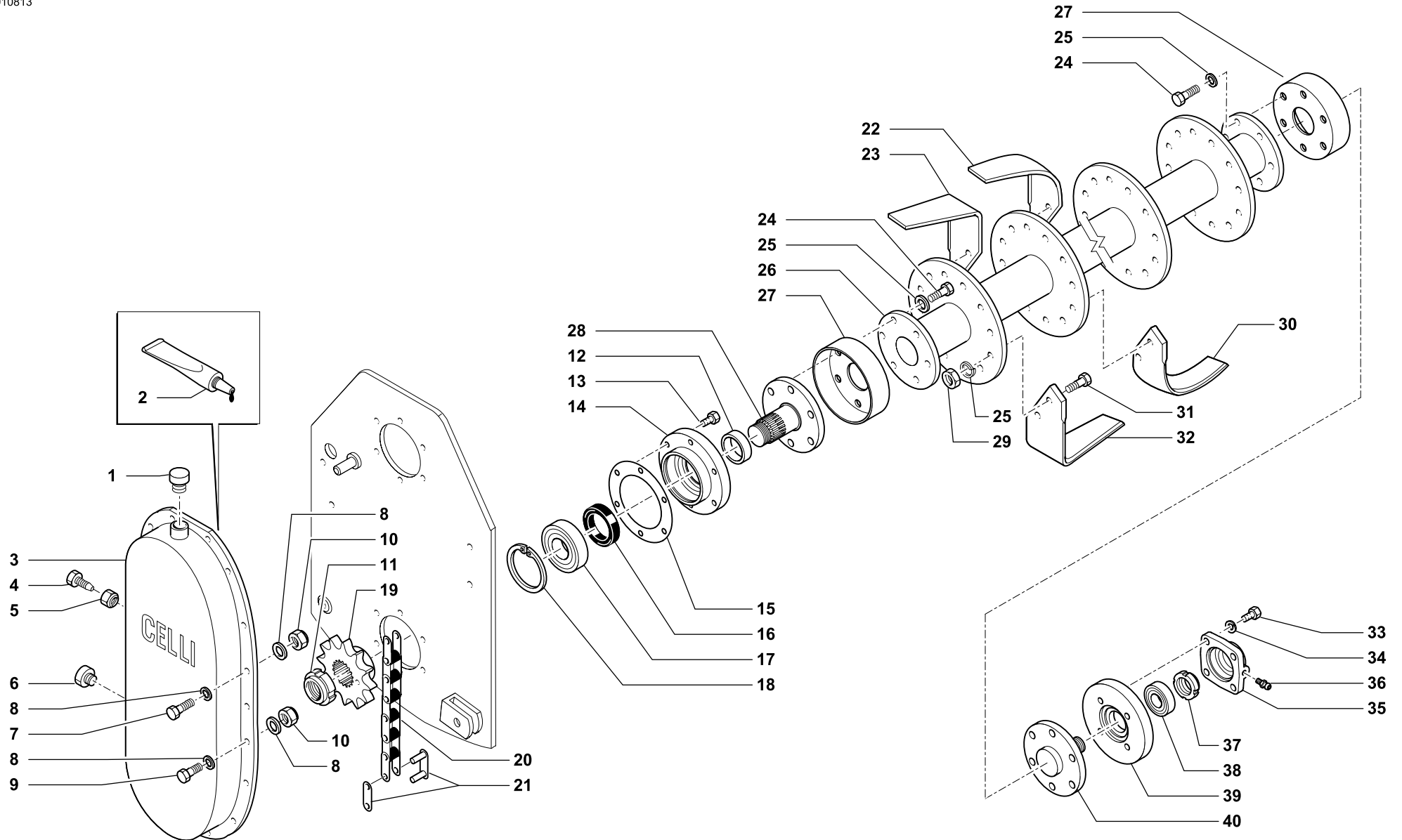



TRANSMISSIONE • TRANSMISSION  
ÜBERTRAGUNG • TRANSMISSION

Tav.  
Tab.  
Taf.

122.467

Rev.

01

0813

RIF.	CODICE	DESCRIZIONE	DENOMINATION	BEZEICHNUNG	DENOMINATION
1	022010	Tappo	Plug	Verschluss	Bouchon
2	094002	Sigillante	Glue	Klebstoff	Colle
3	561602	Carter	Cover	Deckel	Carter
4	523527	Vite	Screw	Schraube	Vis
5	004054	Dado	Nut	Mutter	Ecrou
6	022018	Tappo	Plug	Verschluss	Bouchon
7	014245	Vite	Screw	Schraube	Vis
8	010023	Rondella	Washer	Scheibe	Rondelle
9	014005	Vite	Screw	Schraube	Vis
10	004055	Dado	Nut	Mutter	Ecrou
11	005007	Ghiera	Ring nut	Nutmutter	Collier
12	523509	Distanziale	Spacer	Distanzstueck	Entretoise
13	014165	Vite	Screw	Schraube	Vis
14	521501	Supporto	Support	Halterung	Support
15	324513	Guarnizione	Gasket	Dichtring	Joint
16	007021	Paraolio	Oil seal	Simmerring	Joint huile
17	003138	Cuscinetto	Bearing	Kugellager	Roulement
18	001007	Anello di arresto	Stop ring	Sperring	Bague d'arret
19	523507	Ingranaggio	Gear	Zahnrad	Engrenage
20	009010	Catena	Chain	Kette	Chaine
21	009007	Maglia catena	Outer link	Kettenschloss	Attache de chaine
22	522601	Zappa	Blade	Messer	Lame
23	522603	Zappa	Blade	Messer	Lame
24	014145	Vite	Screw	Schraube	Vis
25	011035	Rosetta	Washer	Scheibe	Rondelle
95	561631	Rotore F	Rotor F	Rotor F	Rotor F
105	561632	Rotore F	Rotor F	Rotor F	Rotor F
125	561634	Rotore F	Rotor F	Rotor F	Rotor F
145	561636	Rotore F	Rotor F	Rotor F	Rotor F
165	561638	Rotore F	Rotor F	Rotor F	Rotor F
95	561698	Rotore D	Rotor D	Rotor D	Rotor D
105	561762	Rotore D	Rotor D	Rotor D	Rotor D

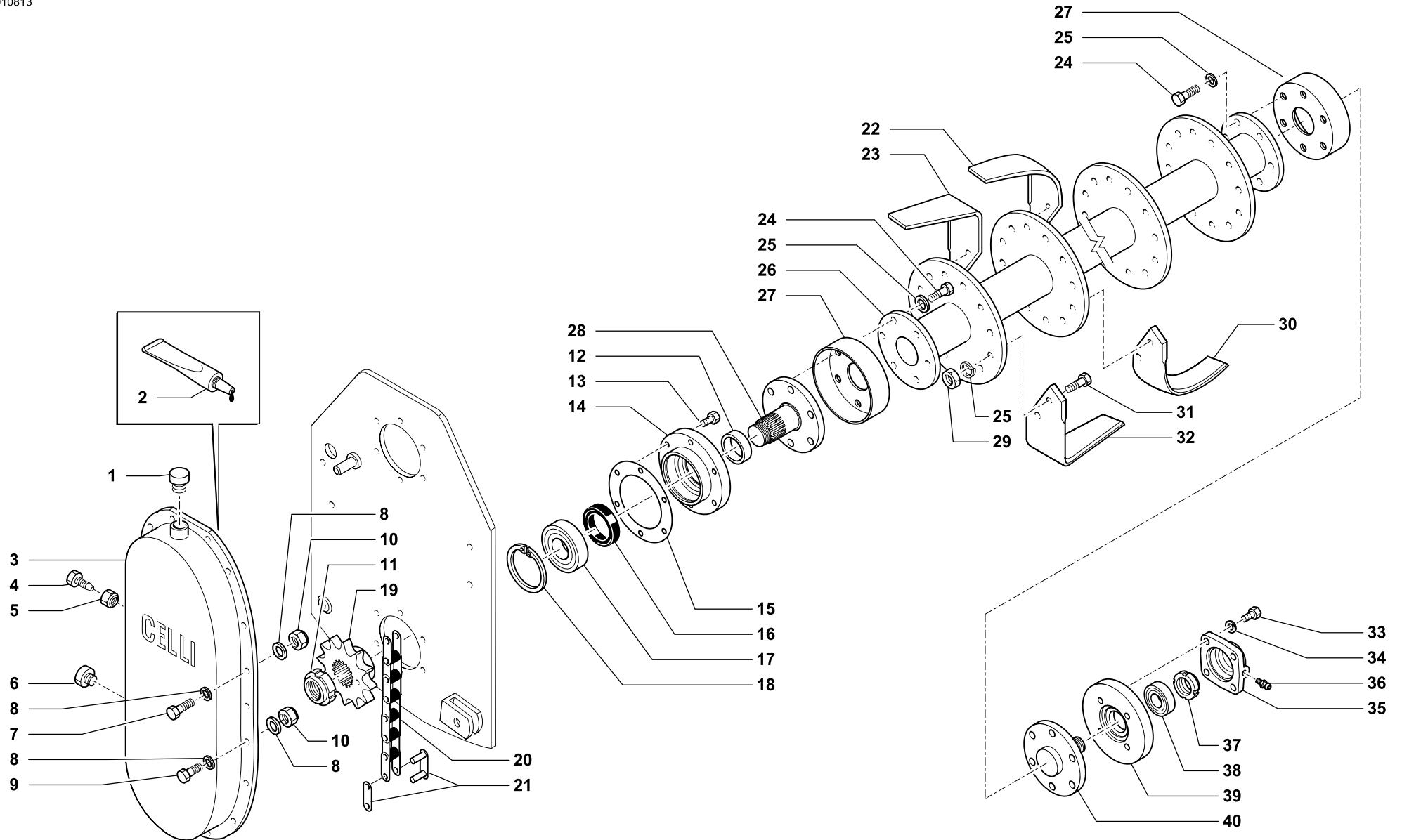



TRANSMISSIONE • TRANSMISSION  
ÜBERTRAGUNG • TRANSMISSION

Tav.  
Tab.  
Taf.

**122.467**

Rev.

**01**

**0813**

RIF.	CODICE	DESCRIZIONE	DENOMINATION	BEZEICHNUNG	DENOMINATION
125	561764	Rotore D	Rotor D	Rotor D	Rotor D
145	561766	Rotore D	Rotor D	Rotor D	Rotor D
165	561768	Rotore D	Rotor D	Rotor D	Rotor D
27	511502	Parapolvere	Dust cover	Staubdeckel	Cache anti poussière
28	522504	Mozzo	Hub	Nabe	Disque
29	004030	Dado	Nut	Mutter	Ecrou
30	522600	Zappa	Blade	Messer	Lame
31	014146	Vite	Screw	Schraube	Vis
32	522602	Zappa	Blade	Messer	Lame
33	014256	Vite	Screw	Schraube	Vis
34	011032	Grower	Grower	Federscheibe	Grower
35	521502	Coperchio	Cover	Deckel	Couvercle
36	008001	Ingrassatore	Grease nipple	Fettbuechse	Graisneur
37	005010	Ghiera	Ring nut	Nutmutter	Collier
38	003120	Cuscinetto	Bearing	Kugellager	Roulement
39	512532	Supporto	Support	Halterung	Support
40	522509	Fusello	Drive hub	Achszapfen	Fusée



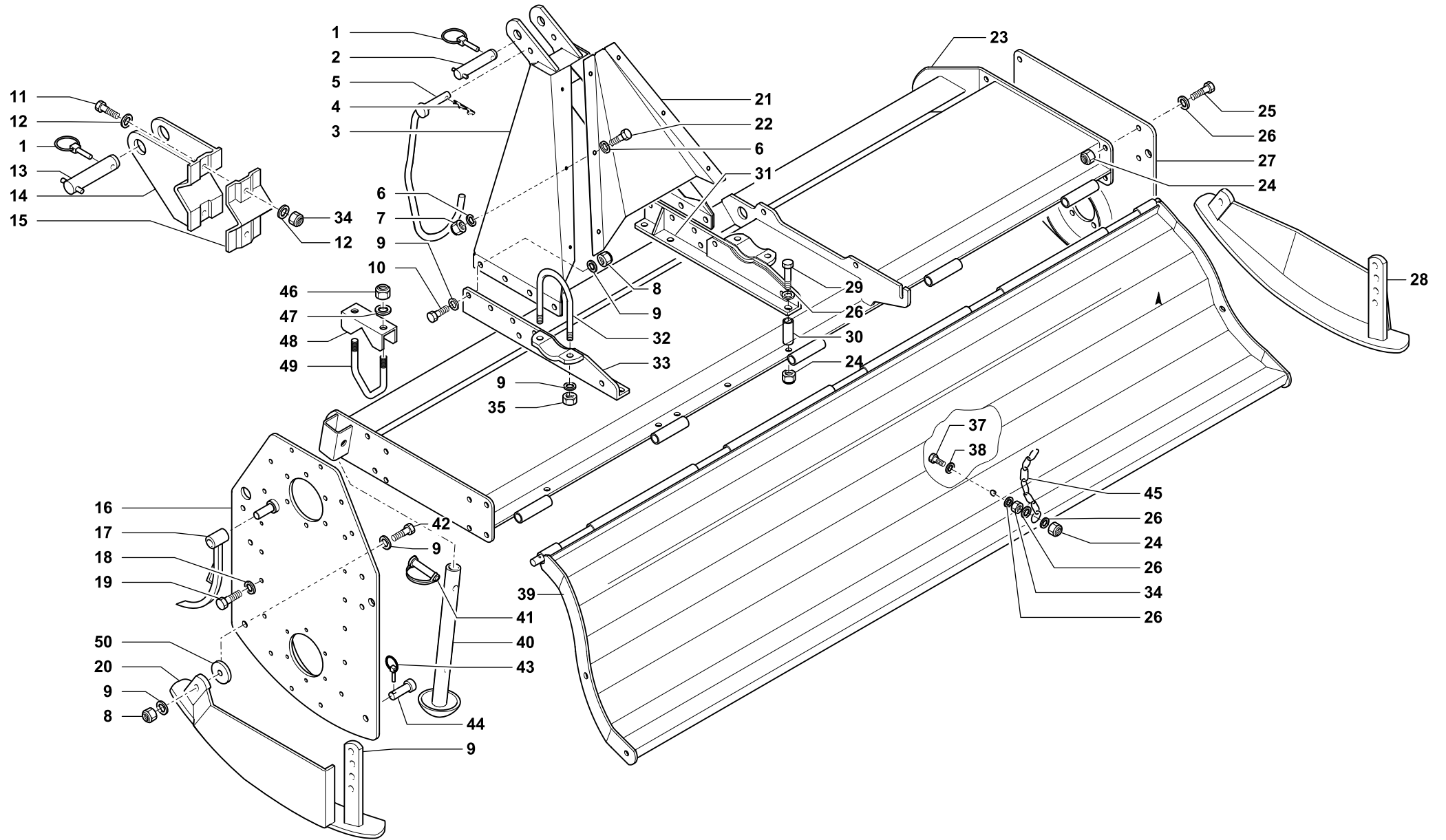

TELAIO • FRAME  
RAHMEN • CHASSIS



TELAIO • FRAME  
RAHMEN • CHASSIS

Tav.  
Tab.  
Taf.

122.366

Rev. 01

0813

RIF.	CODICE	DESCRIZIONE	DENOMINATION	BEZEICHNUNG	DENOMINATION
1	013011	Spina	Pin	Stift	Goupille
2	423743	Perno	Pivot	Bolzen	Axe
3	561822	Castello 3 punto	Third point	Hebe boch	Bati 3 point
	561827	Castello 3 punto allungato	Third point	Hebe boch	Bati 3 point
4	002014	Copiglia	Split pin	Hohlstift	Goupille
5	538534	Gancio	Hook	Haken	Crochet
6	010015	Rondella	Washer	Scheibe	Rondelle
7	004083	Dado	Nut	Mutter	Ecrou
8	004079	Dado	Nut	Mutter	Ecrou
9	010005	Rondella	Washer	Scheibe	Rondelle
10	014256	Vite	Screw	Schraube	Vis
11	014126	Vite	Screw	Schraube	Vis
12	010002	Rondella	Washer	Scheibe	Rondelle
13	523611	Perno	Pivot	Bolzen	Axe
14	561821	Attacco	Hitch	Unterlenker	Attelage
	561826	Attacco allungato	Hitch	Unterlenker	Attelage
15	511523	Morsetto	Clamp	Klemme	Etau
16	561130	Laterale sinistro	L.H. panel	Seitenblench links	Lateral gauche
17	561745	Tendicatena	Chain tensioner	Kettenspanner	Tendeur de chaine
18	011001	Grower	Grower	Federscheibe	Grower
19	014284	Vite	Screw	Schraube	Vis
20	561896	Pattino sinistro	L.H. skid	Linke kufe	Patin gauche
21	511522	Protezione	Protection	Schutz	Protection
22	014061	Vite	Screw	Schraube	Vis
95	23	561122	Telaio	Frame	Châssis
105		561123	Telaio	Frame	Châssis
125		561124	Telaio	Frame	Châssis
145		561125	Telaio	Frame	Châssis
165		561126	Telaio	Frame	Châssis
24	004084	Dado	Nut	Mutter	Ecrou
25	014149	Vite	Screw	Schraube	Vis
26	010004	Rondella	Washer	Scheibe	Rondelle

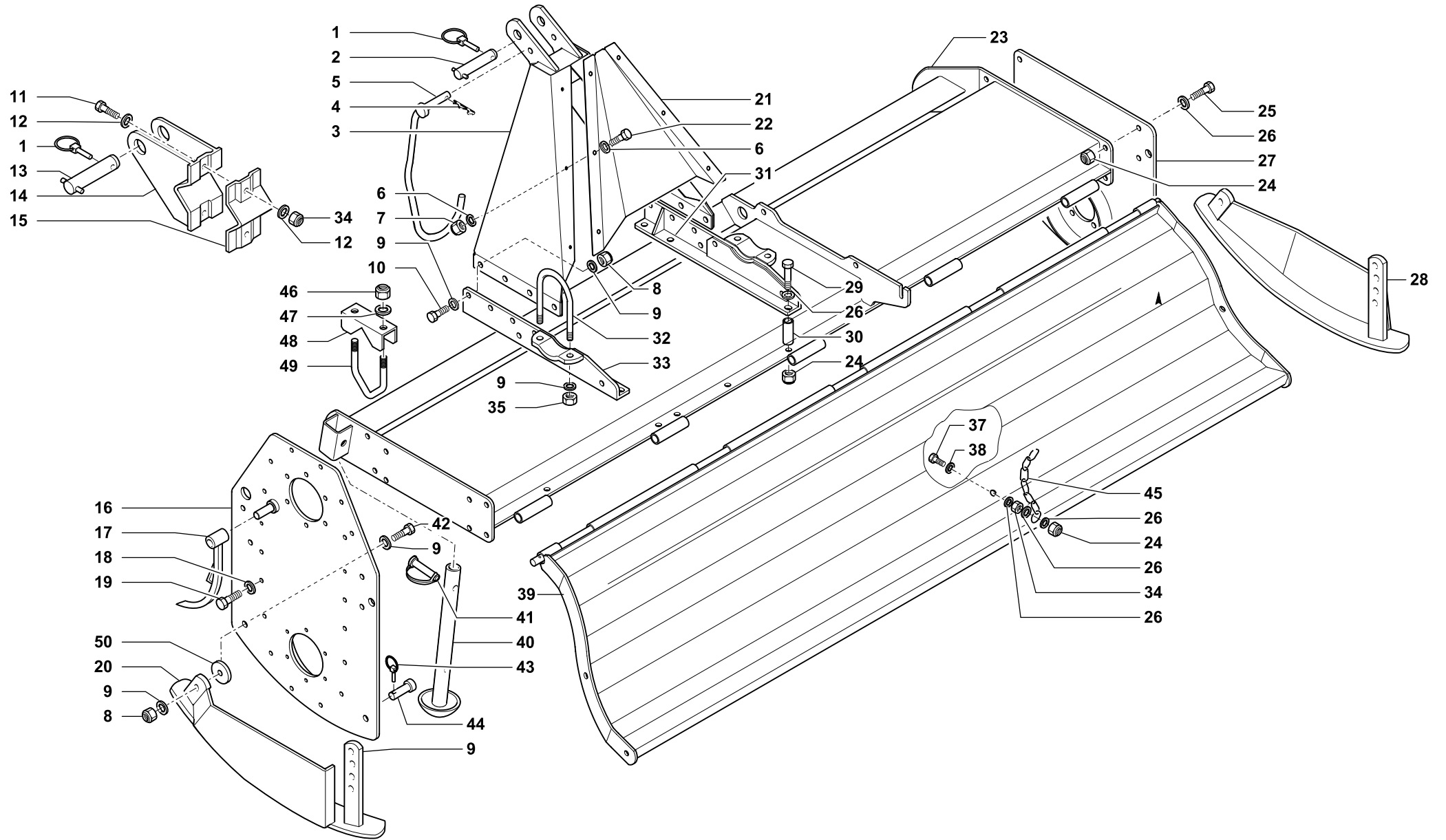

TELAIO • FRAME  
RAHMEN • CHASSIS



TELAIO • FRAME  
RAHMEN • CHASSIS

Tav.  
Tab.  
Taf.

122.366

Rev.

01

0813

RIF.	CODICE	DESCRIZIONE	DENOMINATION	BEZEICHNUNG	DENOMINATION
27	561131	Laterale destro	R.H. panel	Seitenblech	Lateral droite
28	561897	Pattino destro	R.H. skid	Rechte kufe	Patin droite
29	014294	Vite	Screw	Schraube	Vis
30	523685	Distanziale	Spacer	Distanzstueck	Entretoise
31	561823	Traversa	Cross piece	Querbalken	Traverse
32	332510	Cavallotto	U bolt	Bügelbolzen	Crampillon
33	561824	Traversa	Cross piece	Querbalken	Traverse
34	004054	Dado	Nut	Mutter	Ecrou
35	004030	Dado	Nut	Mutter	Ecrou
36	523624	Cerniera	Hinge	Gelenk	Charniere
37	014291	Vite	Screw	Schraube	Vis
38	010021	Rondella	Washer	Scheibe	Rondelle
<b>95</b>	39	566102	Scudo mobile	Rear shield	Tablier arriere
<b>105</b>		566103	Scudo mobile	Rear shield	Tablier arriere
<b>125</b>		566104	Scudo mobile	Rear shield	Tablier arriere
<b>145</b>		566105	Scudo mobile	Rear shield	Tablier arriere
<b>165</b>		566106	Scudo mobile	Rear shield	Tablier arriere
40	961596	Piede	Stand	Stelfuss	Pied
41	013048	Spinotto ad arco	Pin	Stift	Goupille
42	014215	Vite	Screw	Schraube	Vis
43	013006	Spina scatto	Pin	Stift	Goupille
44	532508	Perno	Pin	Zapfen	Pivot
45	009020	Catena	Chain	Kette	Chaine
46	004079	Dado	Nut	Mutter	Ecrou
47	010005	Rondella	Washer	Scheibe	Rondelle
48	534510	Morsetto	Clamp	Klemme	Etau
49	532503	Cavallotto	U bolt	Bügelbolzen	Crampillon
50	334001	Distanziale	Spacer	Distanzstueck	Entretoise

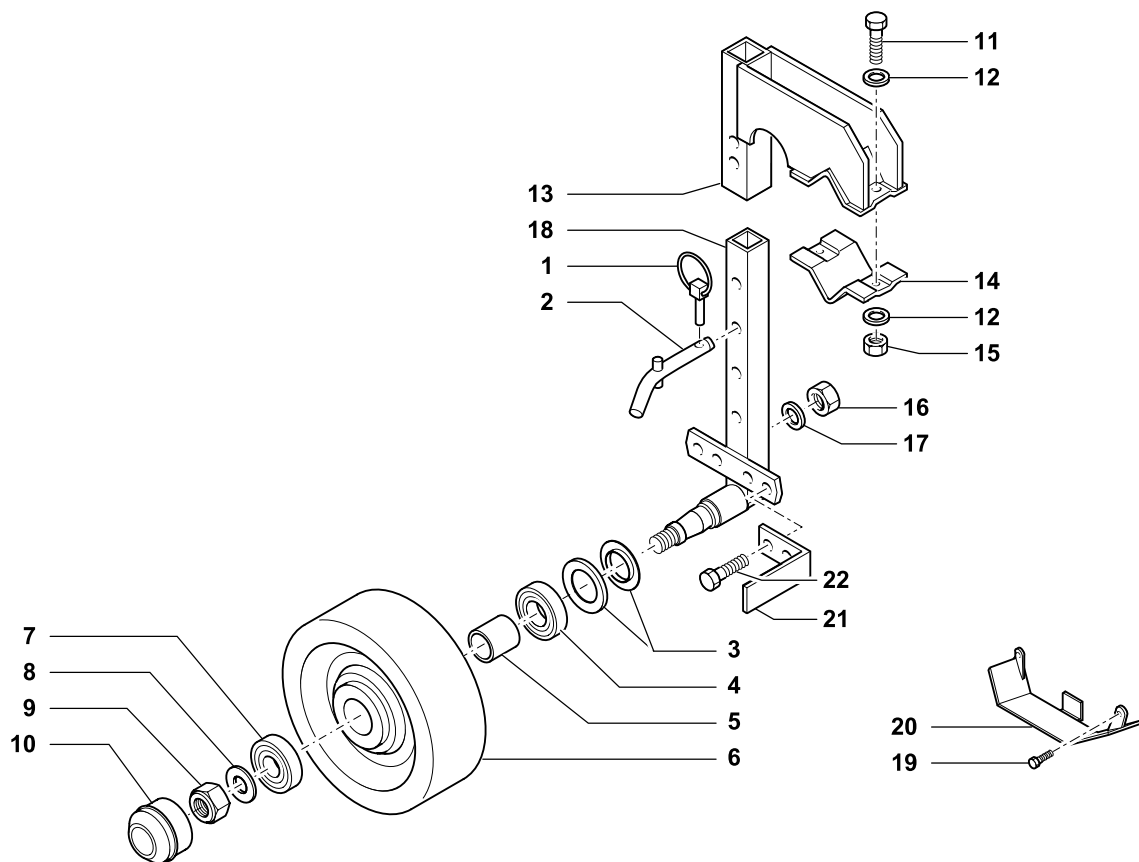



**RUOTE ANTERIORI • FRONT WHEELS**  
**VORDERE RÄDE • ROUES AVANT**

Tav.  
Tab.  
Taf.

**122.367**

Rev. **00**

**0813**

RIF.	CODICE	DESCRIZIONE	DENOMINATION	BEZEICHNUNG	DENOMINATION
1	013023	Spina	Spring pin	Hohlstift	Goupille mecanindus
2	223522	Perno	Pivot	Bolzen	Axe
3	099017	Parapolvere	Dust cover	Staubdichtung	Cache anti poussière
4	003090	Cuscinetto	Bearing	Kugellager	Roulement
5	323596	Boccola	Spacer	Distanzring	Bague
6	015005	Ruota	Wheel	Stutzrad	Roue
7	003059	Cuscinetto	Bearing	Kugellager	Roulement
8	010008	Rondella	Washer	Scheibe	Rondelle
9	004074	Dado	Nut	Mutter	Ecrou
10	015008	Cappello	Cover	Deckel	Couvercle
11	014126	Vite	Screw	Schraube	Vis
12	010002	Rondella	Washer	Scheibe	Rondelle
13	961584	Supporto	Support	Halterung	Support
14	511523	Morsetto	Clamp	Klemme	Etau
15	004054	Dado	Nut	Mutter	Ecrou
16	004058	Dado	Nut	Mutter	Ecrou
17	011002	Grower	Grower	Federscheibe	Grower
18	961588	Tubo	Tube	Rohr	Tube
19	014245	Vite	Screw	Schraube	Vis
20	561769	Protezione	Protection	Schütz	Protection
21	923541	Raschietto	Scraper	Schaber	Racloir
22	014149	Vite	Screw	Schraube	Vis

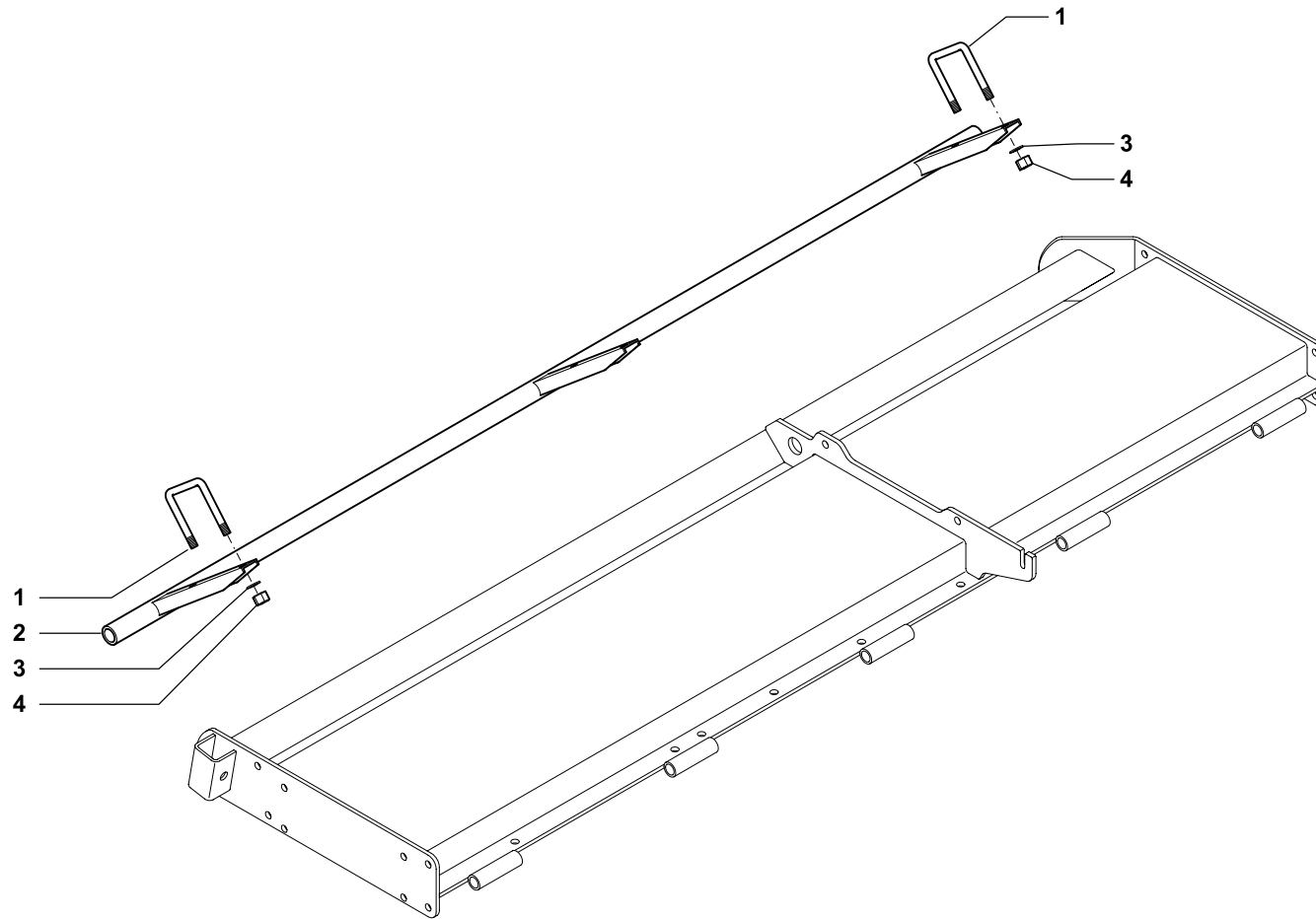



PROTEZIONI ANTINFORTUNISTICHE • SAFETY PROTECTION  
SICHERHEITSSCHUTZ • PROTECTION DE SECURITE

Tav.  
Tab.  
Taf.

122.712

Rev. 00

0813

RIF.	CODICE	DESCRIZIONE	DENOMINATION	BEZEICHNUNG	DENOMINATION
1	913002	Cavallotto	U bolt	Bügelbolzen	Crampillon
2	010004	Rondella	Washer	Scheibe	Rondelle
3	004066	Dado	Nut	Mutter	Ecrou
95	4	662856	Protezione	Schutz	Protection
105		662864	Protezione	Schutz	Protection
125		662857	Protezione	Schutz	Protection
145		662858	Protezione	Schutz	Protection
165		662859	Protezione	Schutz	Protection
95		978731	Kit protezione	Schutz	Protection
105		978733	Kit protezione	Schutz	Protection
125		978735	Kit protezione	Schutz	Protection
145		978736	Kit protezione	Schutz	Protection
165		978737	Kit protezione	Schutz	Protection







1955

**Celli S.p.A.** Via Masetti, 32 - 47122 Forlì (Italy)  
Tel. 0543 794711 - Fax. 0543 794747  
[www.celli.it](http://www.celli.it)